

PRELIMINARY

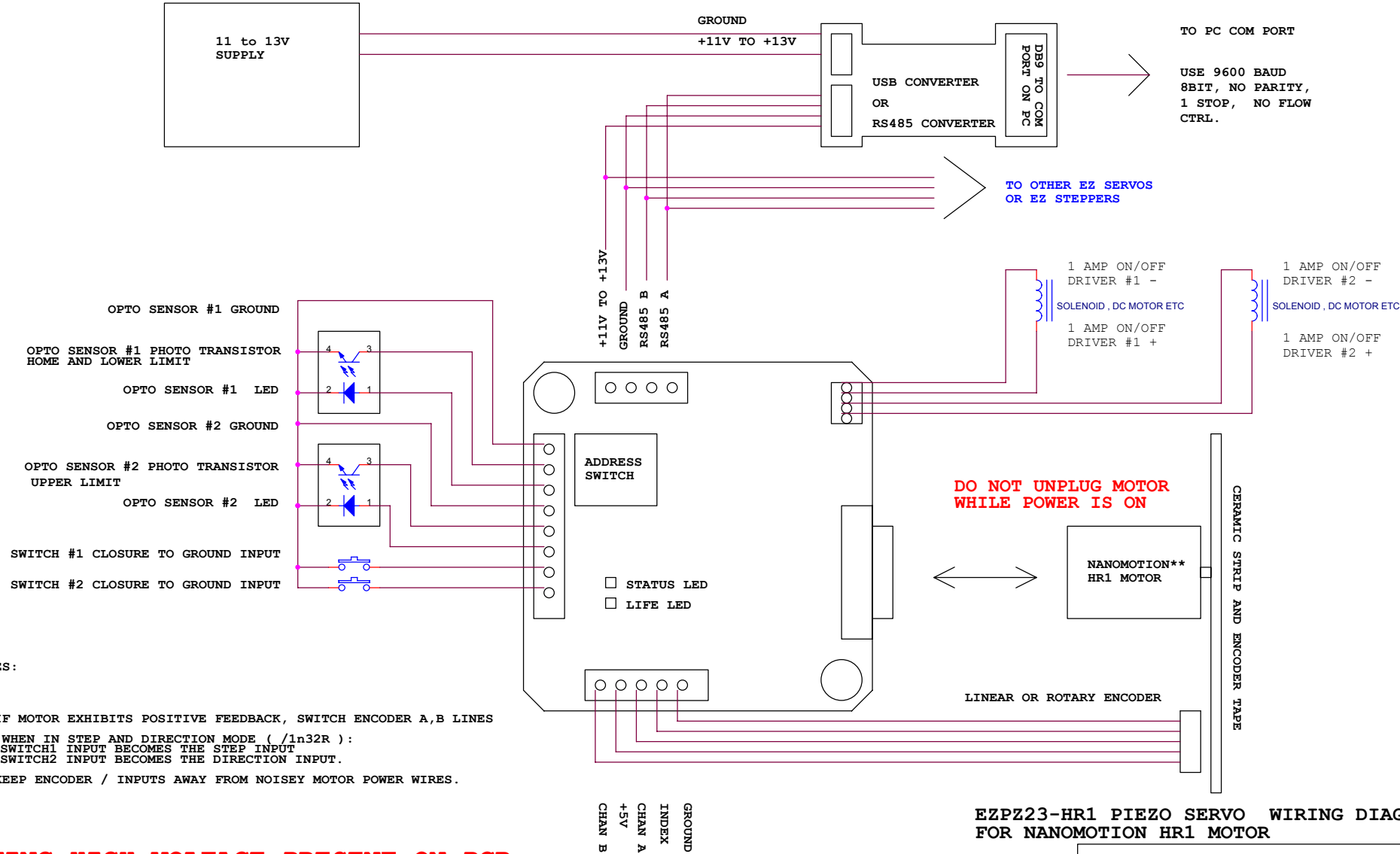

NOTES:

- 1) IF MOTOR EXHIBITS POSITIVE FEEDBACK, SWITCH ENCODER A,B LINES
- 2) WHEN IN STEP AND DIRECTION MODE (/ln32R):
SWITCH1 INPUT BECOMES THE STEP INPUT
SWITCH2 INPUT BECOMES THE DIRECTION INPUT.
- 3) KEEP ENCODER / INPUTS AWAY FROM NOISEY MOTOR POWER WIRES.

WARNING HIGH VOLTAGE PRESENT ON PCB

** THIS DRIVE IS NOT APPROVED BY NANOMOTION.

NOTE: ENCODER SIGNALS MUST BE >4.5V HIGH LEVEL.
THIS MAY REQUIRE EXTERNAL PULLUPS.

COPYRIGHT ALLMOTION.COM

**EZPZ23-HR1 PIEZO SERVO WIRING DIAGRAM
FOR NANOMOTION HR1 MOTOR**

Title		ALLMOTION.COM EZPZ23-HR1 WIRING DIAGRAM	
Size	Document Number	Rev	
B		A1	
Date:	Tuesday, June 19, 2007	Sheet	1 of 4

EZPZ23-HR1 ACESSORIES AND OTHER ELECTRICAL NOTES

MATING CONNECTORS:

AMP MTA 100 SERIES

4PIN 22 GA DIGIKEY P/N A23849 (INPUT CONNECTOR)

8PIN 22 GA DIGIKEY P/N A23841 (NEMA23 MOTOR)

8PIN 24 GA DIGIKEY P/N A23820 (NEMA17 MOTOR)

8PIN 26 GA DIGIKEY P/N A23799 (FOR OPTOS)

5PIN 26 GA DIGIKEY P/N A23796 (FOR ENCODER)

T HANDLE CRIMP TOOL DIGIKEY P/N A9982

OPTO HOME SWITCH:

- 1) "Z" OR HOME COMMAND RUNS MOTOR UNTIL OPTO #1 IS ON FLAG EDGE.
- 2) AN OPTO SWITCH PROVIDED WITH EACH STARTER KIT
- 3) USE TRANSISTOR OPTO THAT HAS $I_c > 1\text{mA}$ @ $I_F = 20\text{mA}$.
- 4) EXAMPLES OF ACCEPTABLE OPTOS ARE:

DIGIKEY P/N QVA11134

DIGIKEY P/N H21A1

HONEYWELL HOA1887-012 (IS PREWIRED)

HONEYWELL HOA1870-33 (IS PREWIRED)

OPTEK OPB830W11 (IS PREWIRED)

5) THE OPTO COUPLER LED PIN HAS 200 OHM TO 5V IN SERIES ON THE BOARD. THE 200 OHM CAN BE REMOVED IF DESIRED FOR RUNNING SENSORS THAT REQUIRE DIRECT ACCESS TO 5V. (OR USE ENCODER 5V POWER) THE COLLECTOR OF THE TRANSISTOR HAS A 10K PULLUP TO 5V. THE TOTAL CURRENT DRAWN FROM THE 5V SUPPLY (INCLUDING OPTOS) MUST BE LESS THAN 200mA.

6) ALL INPUTS ARE 0-3.3V ADC INPUTS, THE ONE/ZERO THRESHOLD IS FACTORY SET TO 1.23V, TO BE TTL COMPATIBLE, AND CAN BE CHANGED BY SOFTWARE COMMAND.

ON/OFF DRIVERS ALTERNATE WIRING DIAGRAM

1) ON/OFF DRIVERS RATED AT 2 AMPS PEAK, 1 AMP CONTINUOUS.

2) THE NEGATIVE PIN OF THESE DRIVERS IS ACTUALLY AN OPEN COLLECTOR TYPE OUTPUT THAT PULLS DOWN TO GROUND. IT IS POSSIBLE TO DRIVE LOADS THAT ARE OF A DIFFERENT VOLTAGE THAN THE SUPPLY VOLTAGE, BY CONNECTING THE POSITIVE SIDE OF THE LOAD TO AN EXTERNAL SUPPLY, AND THE NEGATIVE SIDE TO THE -VE OUTPUT PIN. HOWEVER, IN CASE THIS IS DONE IT IS NECESSARY TO PLACE AN EXTERNAL "FREE WHEELING" DIODE ACROSS ANY INDUCTIVE LOADS. EXTERNAL SUPPLY VOLTAGE MUST BE LESS THAN SUPPLY VOLTAGE TO EZ STEPPER

3) EXTERNAL DIODE IS NOT NECESSARY IF BOTH SIDES OF LOAD ARE WIRED BACK TO THE EZ STEPPER.

ON/OFF DRIVERS ALTERNATE WIRING DIAGRAM

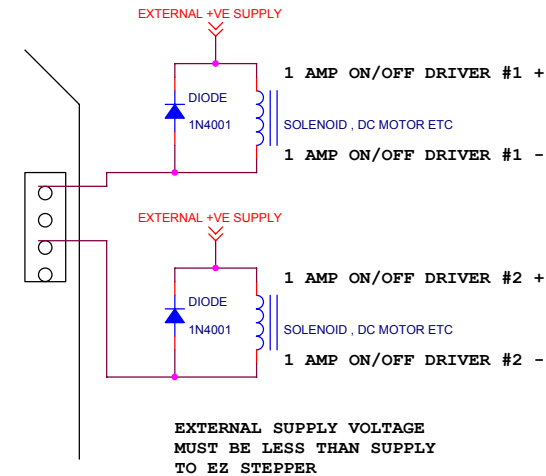

WARNING HIGH VOLTAGE PRESENT ON PCB

SEE NEXT PAGE FOR DIMENSIONAL INFO

COPYRIGHT ALLMOTION.COM

Title		
ALLMOTION.COM EZPZ23-HR1 WIRING DIAGRAM		
Size	Document Number	Rev
B		A1
Date:	Tuesday, June 19, 2007	Sheet 2 of 4

PRELIMINARY

- FEEDBACK POT1 GROUND
- FEEDBACK POT1 WIPER
- FEEDBACK POT1 POWER

- POSITION COMMAND POT2 GROUND
- POSITION COMMAND POT2 WIPER
- POSITION COMMAND POT2 POWER

- SWITCH #1 CLOSURE TO GROUND INPUT
- SWITCH #2 CLOSURE TO GROUND INPUT

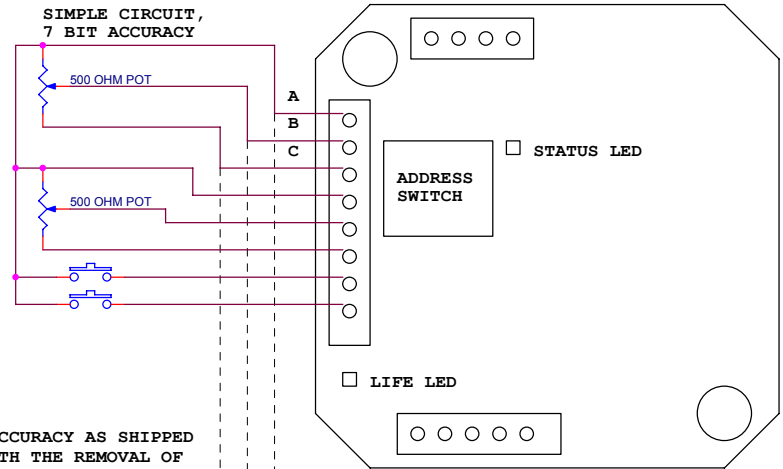

DO NOT UNPLUG MOTOR WHILE POWER IS ON

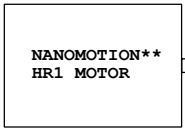

NOTES:

- 1) ALL 4 INPUTS ARE ANALOG INPUTS
- 2) ADC's VALUES RANGE FROM 0-16368. THE ACCURACY AS SHIPPED IS 7 BIT BUT CAN BE IMPROVED TO >10BIT WITH THE REMOVAL OF THE INPUT PROTECTION CIRCUITRY, CONTACT FACTORY FOR DETAILS
- 3) POTS IN THE RANGE OF 500 OHM - 10K ARE SUGGESTED, LOWER VALUES ARE LESS AFFECTED BY INTERNAL 10K PULLUP. 500 OHM RECOMMENDED.
- 4) IF USING POT FOR POSITION FEED BACK WITH /1N3R MODE, IF MOTOR EXHIBITS POSITIVE FEEDBACK, SWITCH ENDS OF POT
- 5) 10K INTERNAL PULLUP WILL INTERFERE WITH LINEARITY OF POT VOLTAGE, AND MAY NEED TO BE REMOVED - CONTACT FACTORY.
- 6) INPUT OVERVOLTAGE PROTECTION CIRCUITRY MAY NEED TO BE REMOVED FOR >7BIT ACCURACY - CONTACT FACTORY.

WARNING HIGH VOLTAGE PRESENT ON PCB

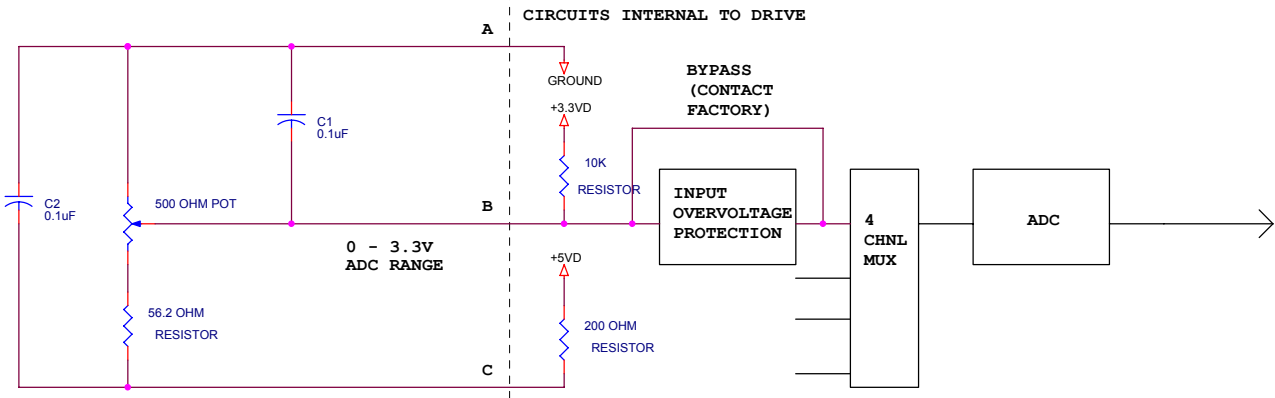

ENHANCED EXTERNAL CIRCUIT FOR > 10BIT ACCURACY

WIRING DIAGRAM ANALOG INPUT OR POTENTIOMETER FEEDBACK

Title		
ALLMOTION.COM EZ SERVO WIRING DIAGRAM		
Size	Document Number	Rev
B		A1
Date: Tuesday, June 19, 2007		
Sheet 3 of 4		

** THIS DRIVE IS NOT APPROVED BY NANOMOTION.

COPYRIGHT ALLMOTION.COM

PRELIMINARY

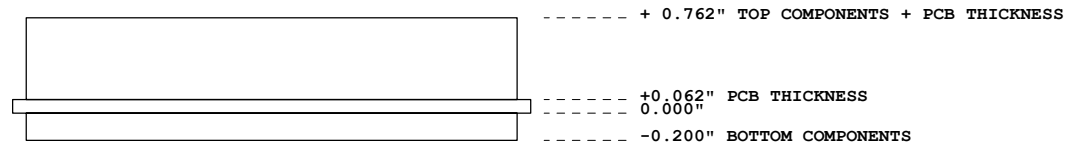
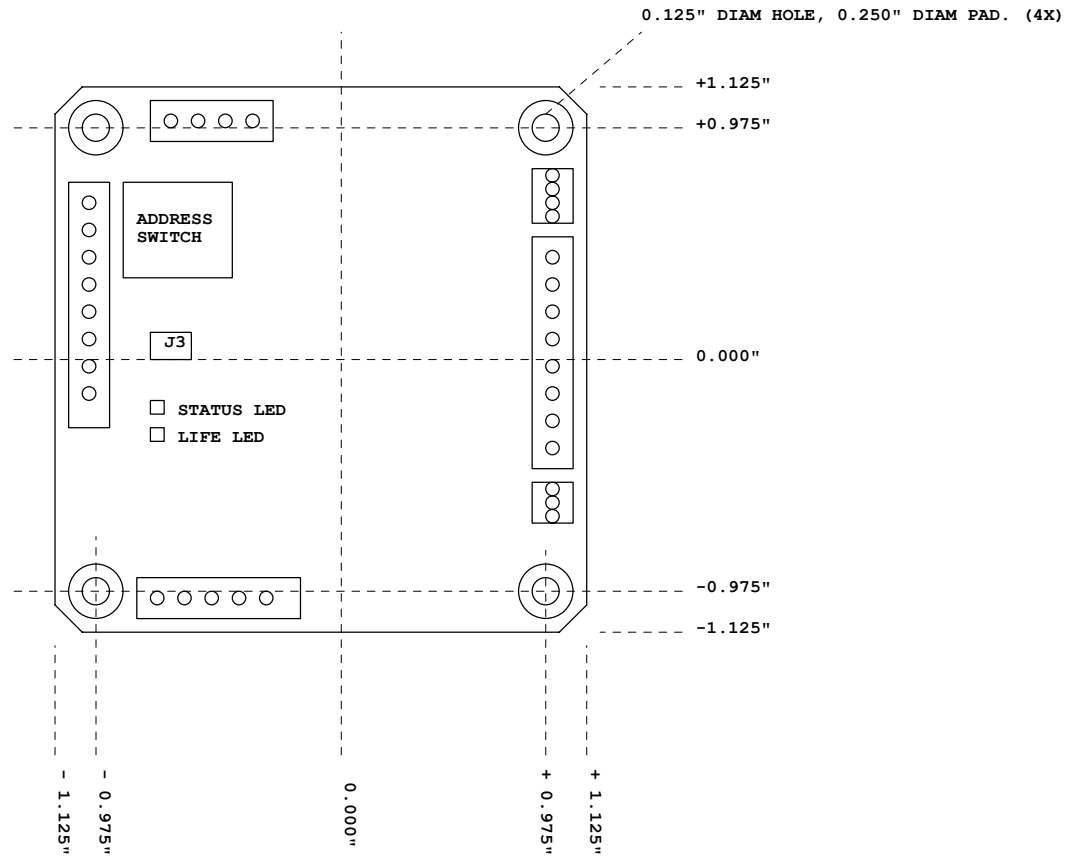

WARNING HIGH VOLTAGE PRESENT ON PCB

EZPZ23-HR1 DIMENSIONAL INFORMATION

COPYRIGHT ALLMOTION.COM

Title		
ALLMOTION.COM EZPZ23-HR1 DIMENSIONAL INFO		
Size	Document Number	Rev
B		A1
Date: Tuesday, June 19, 2007		
Sheet		4 of 4
E		